

# R.W. CONKLINSTEEL

100% Melted & Manufactured in the USA

1-888-CONKLIN (266-5546)

www.conklinsteel.com



## PIPE PILING SPLICERS

*Specifications*

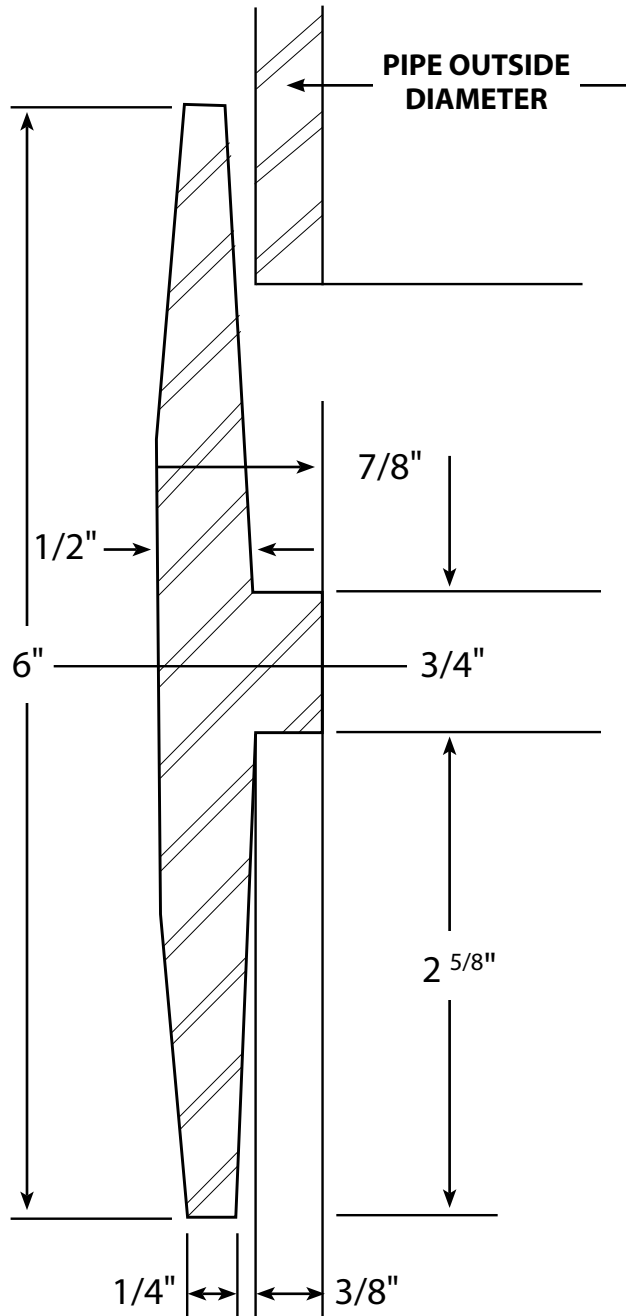

Section through pipe and splicer before driving.

## DRIVE-FIT SPLICER SLEEVE

Pipe Piling splicers are available in all pipe sizes. Pipe splicers help ease alignment of pipe and drive fit with no welding required.

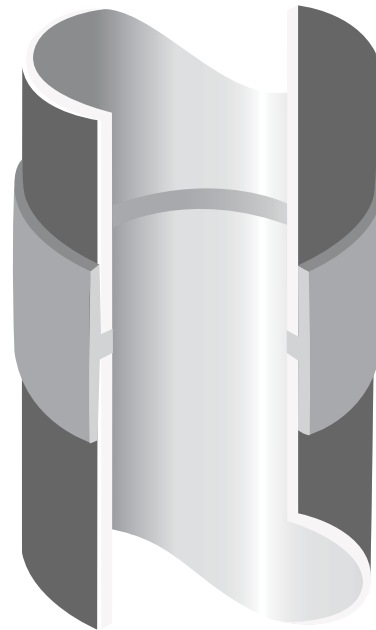

Diameter at this point (1" from each end) is approximately equal to pipe outside diameter (to allow for drive-fit.)

<b>PIPE OUTSIDE DIAMETER</b>	7 5/8"	8"	8 5/8"	9 5/8"
	10"	10 3/4"	12"	
	12 3/4"	14"	16"	
	18"	20"	24"	

# R.W. CONKLINSTEEL

100% Melted & Manufactured in the USA

1-888-CONKLIN (266-5546)

[www.conklinsteel.com](http://www.conklinsteel.com)



## PIPE PILING SPLICERS

*Specifications*

### WELD-FIT SPLICER SLEEVE

Pipe Piling splicers are available in all pipe sizes.

<b>PIPE OUTSIDE DIAMETER</b>	7 5/8"	8"	8 5/8"	9 5/8"
	10"	10 3/4"	12"	
	12 3/4"	14"	16"	
	18"	20"	24"	

